

JAW COUPLING

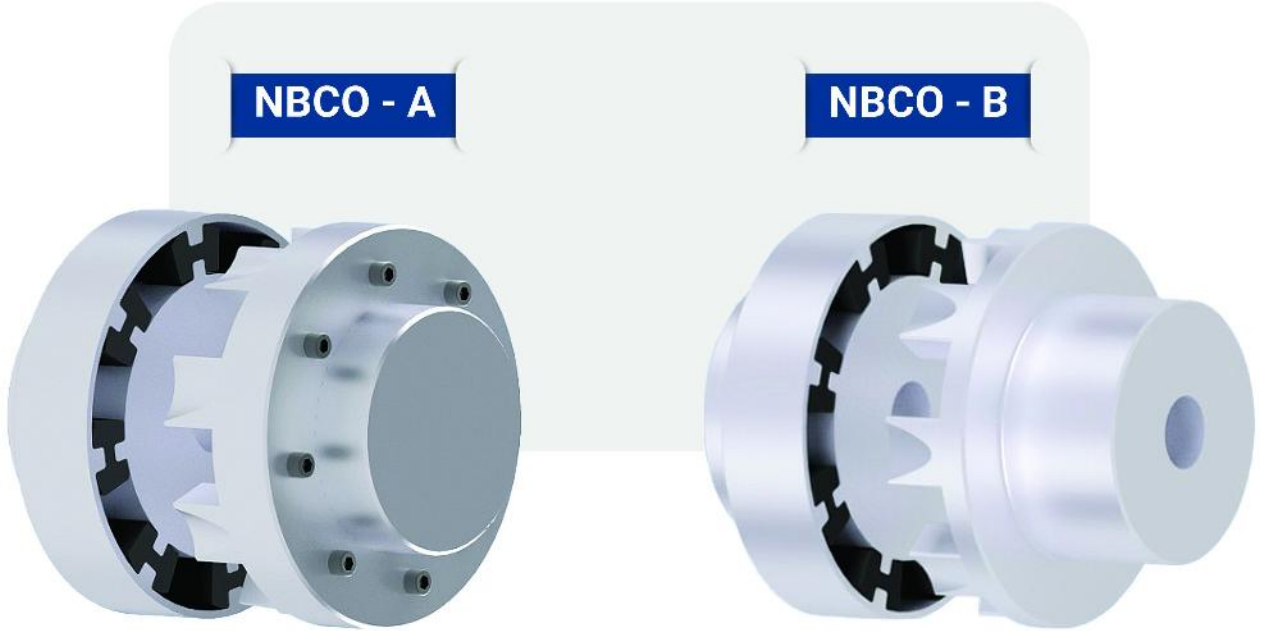

تلفن: ۴۴۰۰۴۱۰۰، ۴۴۰۰۴۲۰۰ (۰۲۱) فکس: ۴۴۰۴۷۵۴۱ (۰۲۱) کدپستی: ۱۴۷۱۸۳۶۸۳۷

تهران، بزرگراه ستاری، تقاطع حکیم، کوچه عزتی پور، پلاک ۶ واحد ۱۰

info@baffco.com

www.BAFFCO.com

همراه امروز، در اندیشه فردا

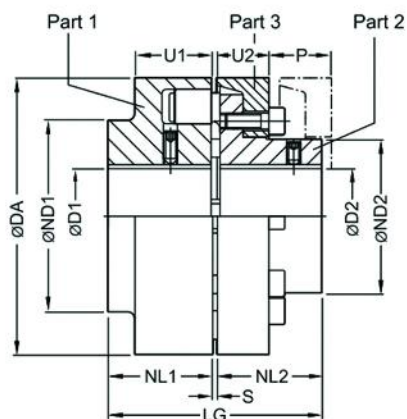
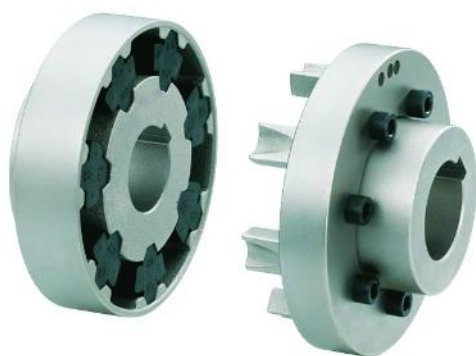

Size	Normal Torque NM	Max Speed RPM	Bore D1		Bore D2		DA	Nd1	Nd2	NL1/ NL2	S	U1	U2	P	LG
			min	max	min	max									
110	160	5300	-	48	-	38	110	86	62	40	3	34	20	33	83
125	240	5100	-	55	-	45	125	100	75	50	3	36	23	38	103
140	360	4900	-	60	-	50	140	100	82	55	3	34	28	43	113
160	560	4250	-	65	-	58	160	108	95	60	4	39	28	47	124
180	880	3800	-	75	-	65	180	125	108	70	4	42	30	50	144
200	1340	3400	-	85	-	75	200	140	122	80	4	47	32	53	164
225	2000	3000	-	90	-	85	225	150	138	90	4	52	38	61	184
250	2800	2750	46	100	46	95	250	165	155	100	6	60	42	69	206

❖ متریال این مدل کوپلینگ چدن GG25 می باشد.

❖ کوپلینگ ها با واسطه لاستیکی با سختی SH/A 80 عرضه می شوند.

❖ وزن کالا با توجه به قطر سوراخ هاب متفاوت می باشد.

❖ مشخصات فنی و ابعادی کوپلینگ ها مطابق با کوپلینگ های انیوپکس می باشند.

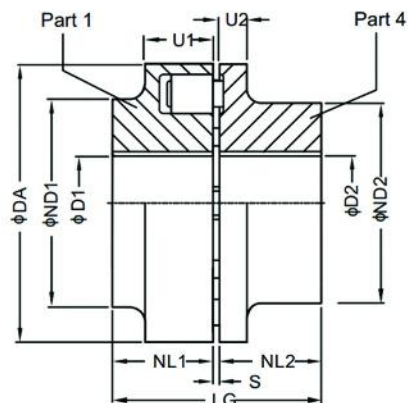

Size	Normal Torque NM	Max Speed RPM	Bore D1		Bore D2		DA	Nd1	Nd2	NL1/ NL2	S	U1	U2	LG
			min	max	min	max								
58	19	7500	-	19	-	24	58	58	40	20	3	20	8	43
68	34	7000	-	24	-	28	68	68	50	20	3	20	8	43
80	60	6000	-	30	-	38	80	80	68	30	3	30	10	63
95	100	5500	-	42	-	42	95	76	76	35	3	30	12	73
110	160	5300	-	48	-	48	110	86	86	40	3	34	14	83
125	240	5100	-	55	-	55	125	100	100	50	3	36	18	103
140	360	4900	-	60	-	60	140	100	100	55	3	34	20	113
160	560	4250	-	65	-	65	160	108	108	60	4	39	20	124
180	880	3800	-	75	-	75	180	125	125	70	4	42	20	144
200	1340	3400	-	85	-	85	200	140	140	80	4	47	24	164
225	2000	3000	-	90	-	90	225	150	150	90	4	52	18	184
250	2800	2750	46	100	46	100	250	165	165	100	5.5	60	18	205.5

Jaw Coupling type NBCO - H

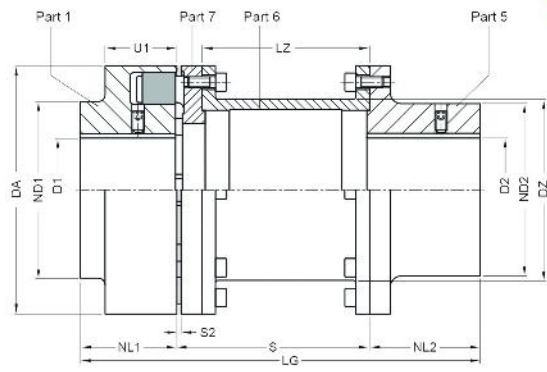

Size	Rated Torque Flexible Type 80 shore A T_{kn} Nm	Speed n_{kmax} rpm	Dimensions in mm Bore with keyway to DIN 6885																
			D1 Min. Max.		D2 Min. Max.		DA	ND1	ND2	NL1	NL2	S2	S	LZ	DZ	LG			
80	60	6000		30	10	32	80	80	55	30	45	3	100	87	51	175			
														140	127		215		
95	100	5500		42	10	42	95	76	70	35	45	3	100	87	63	180			
														140	127		220		
110	160	5300		48	10	48	110	86	80	40	50	3	100	85	73	190			
			50								140		125				230		
			60								180		165					280	
			70								200		185						
125	240	5100		55	10	55	125	100	90	50	50	3	100	85	85	200			
			50								140		125				240		
			60								180		165					290	
			70								200		185						320
			70								200		185						
140	360	4900		60	10	60	140	100	100	55	65	3	100	82	91	220			
			65								140		122				260		
			65								180		162					300	
			65								200		182						320
			65								200		182						
160	560	4250		65	20	65	160	108	108	60	70	4	100	81.5	111	230			
			70								140		121.5				270		
			70								180		161.5					310	
			70								200		181.5						330
			70								200		181.5						
180	880	3800		75	20	75	180	125	125	70	80	4	140	121.5	131	290			
			180										161.5				330		
			200										181.5					350	
			250										231.5						400
			250										231.5						
200	1340	3400		85	20	85	200	140	140	80	90	4	140	118.5	144	310			
			180										158.5				350		
			200										178.5					370	
			250										228.5						420
			250										228.5						
225	2000	3000		90	20	90	225	150	150	90	100	4	140	118.5	169	330			
			180										158.5				370		
			200										178.5					390	
			250										228.5						440
			250										228.5						
250	2800	2750		100	20	100	250	165	165	100	110	5.5	180	152.5	185	390			
			200										172.5				410		
			250										222.5					460	
			250										222.5						